

GILERA WOULD LIKE TO THANK YOU

All manuals and user guides at [all-guides.com](http://all-guides.com)

for choosing one of its products. We have prepared this manual to help you to get the very best from your vehicle. Please read it carefully before riding the vehicle for the first time. It contains information, tips and precautions for using your vehicle. It also describes features, details and devices to assure you that you have made the right choice. We believe that if you follow our suggestions, you will soon get to know your new scooter and it will serve you well for a long time to come. This booklet forms an integral part of the vehicle; should the vehicle be sold, it must be transferred to the new owner.

## Runner PureJet 50



*all-guides.com*

The instructions given in this booklet are intended to provide a clear, simple guide to using your scooter; details are also given of routine maintenance procedures and regular checks that should be carried out on the vehicle at and **Authorized PIAGGIO Dealer or Service Centre**. The booklet also contains instructions for simple repairs. Any operations not specifically described in this booklet require the use of special tools and/or particular technical knowledge: to carry out these operations refer to any **authorized PIAGGIO Dealer or Service Centre**.



### **Personal safety**

Failure to completely observe these instructions will result in serious risk of personal injury.



### **Safeguarding the environment**

Sections marked with this symbol indicate the correct use of the vehicle to prevent damaging the environment.



### **Vehicle intactness**

The incomplete or non-observance of these regulations leads to the risk of serious damage to the vehicle and sometimes even the invalidity of the guarantee.

*The signs that you see on this page are very important. They are used to highlight parts of the booklet that should be read with particular care. The different symbols are used to make each topic in the manual simple and quick to locate.*



## INDEX

<b>VEHICLE</b> .....	7	Checking the electrolyte level.....	34
Dashboard.....	8	Long periods of inactivity.....	34
Key switch.....	10	Fuses.....	35
Locking the steering wheel.....	10	Front light group.....	37
Releasing the steering wheel.....	10	Headlight adjustment.....	38
Switch direction indicators.....	11	Front direction indicators.....	38
Horn button.....	11	Rear optical unit.....	39
Light switch.....	12	Rear-view mirrors.....	39
Start-up button.....	12	Front and rear disc brake.....	39
Opening the saddle.....	12	Puncture.....	40
Keys.....	13	Periods of inactivity.....	41
Identification.....	14	Cleaning the vehicle.....	41
<b>USE</b> .....	15	<b>TECHNICAL DATA</b> .....	47
Checks.....	16	Toolkit.....	52
Refuelling.....	16	<b>SPARE PARTS AND ACCESSORIES</b> .....	53
Tyre pressure.....	18	Warnings.....	54
Running in.....	19	<b>SCHEDULED MAINTENANCE</b> .....	55
Starting up the engine.....	20	Scheduled servicing table.....	56
Difficult start up.....	21		
Stopping the engine.....	21		
Catalytic silencer.....	21		
Automatic transmission.....	22		
Safe driving.....	23		
Air conveyors.....	24		
<b>MAINTENANCE</b> .....	25		
Hub oil level.....	26		
Tyres.....	27		
Spark plug dismantlement.....	28		
Removing the air filter.....	29		
Air filter cleaning.....	29		
Cooling fluid level.....	30		
Checking the brake oil level.....	31		
Battery.....	33		



*all-guides.com*



# Runner PureJet 50



**Chap. 01**  
**Vehicle**

## Dashboard (01\_01)

**A** = Speedometer

**B** = Odometer

**C** = Fuel gauge

**D** = Coolant temperature gauge

**E** = Turn signal indicator

**F** = Engine two-stroke oil

**G** = High beam indicator

**H** = Fuel warning light

**I** = Light indicator

**L** = Plug with contacts

**M** = Turn signal selector

**N** = Horn

**O** = Starter button

**P** = Throttle

**Q** = Front brake lever

**R** = Rear brake lever

**S** = WARNING light (injection fault warning)\*

**T** = High/dipped beam switch

**U** = Trip odometer

**V** = Trip odometer reset button

**Z** = Light

(\*) The indicator is directly managed by the injection control unit in a non-continuous manner with five discrete levels.

(\*) Check the light when the key is set to "ON":

Running engine: with light off: (OK)

with solid light on: (contact the concessionarie as soon as possible)

with flashing light: (stop immediately, turn the engine off, wait a few minutes before restarting). Contact the **concession-aire or an author-ised PIAGGIO-GILERA Service Centre.**

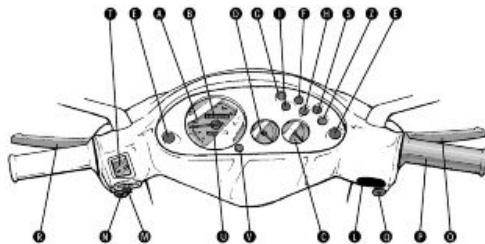

01\_01

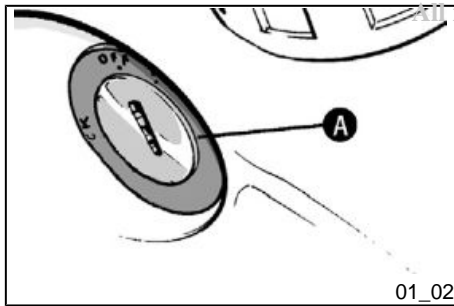

Key switch (01\_02) [all-guides.com](http://all-guides.com)

**LOCK**= Ignition blocked, key can be extracted, steering lock installed.

**OFF** = Ignition blocked, key can be extracted, steering lock not on.

**ON** = Starter position, steering lock not on, key cannot be extracted.

### Locking the steering wheel

Turn the handlebar to the left (as far as it will go), turn the key to «**LOCK**» and remove the key.

#### CAUTION



**NEVER TURN THE KEY TO «LOCK» OR «OFF» WHILE RIDING.**

### Releasing the steering wheel

Reinsert the key and turn it to «**OFF**».

#### CAUTION



**NEVER TURN THE KEY TO «LOCK» OR «OFF» WHILE RIDING.**

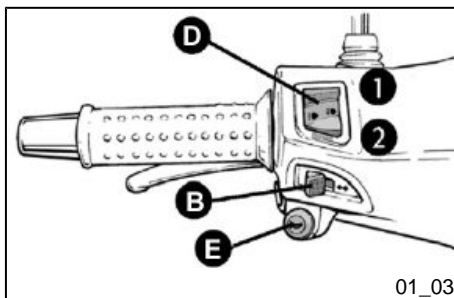

**Switch direction indicators (01\_03)**

To set the left turn indicators flashing, move lever «B» to the left; to set the right turn indicators flashing, move it to the right. The lever automatically returns to the central position and the indicators remain on. To turn the indicators off, press the lever towards the switch.

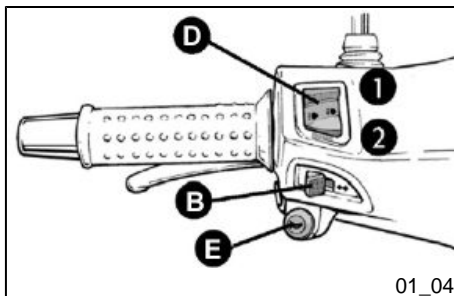

**Horn button (01\_04)**

Horn button «E»

*all-guides.com*

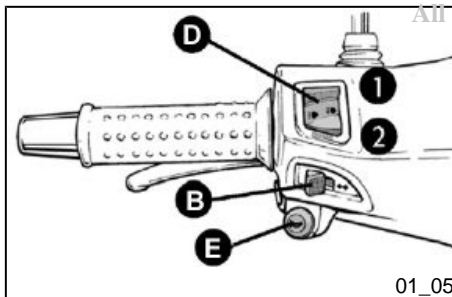

### Light switch (01\_05)

0 = Low-beam and tail light

1 = High-beam and tail light

01\_05

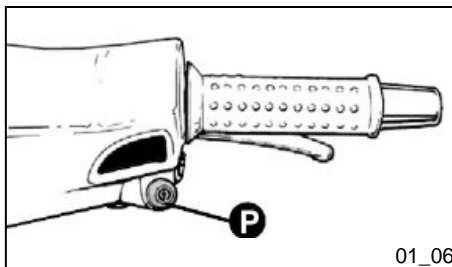

### Start-up button (01\_06)

To start the engine, press the starter button, «P», after pulling either one of the two brake levers.

01\_06

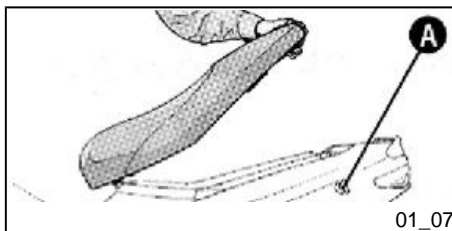

### Opening the saddle (01\_07, 01\_08)

Insert the key in lock «A», turn it anticlockwise and tip the saddle forward.

After having tipped the saddle, place the helmet as shown in the figure.

01\_07

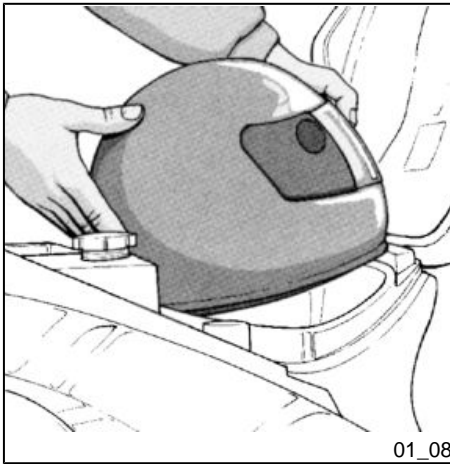

### Keys (01\_09)

The vehicle is supplied with two keys (one spare) that serve to start the engine, open the fuel tank and unlock the saddle compartment.

The keys are accompanied by a plate marked with the identification code to be quoted when ordering duplicates.

#### **WARNING**

**WE RECOMMEND KEEPING THE DUPLICATE KEY TOGETHER WITH ITS CODE IN A SAFE PLACE AND NOT ON THE VEHICLE**





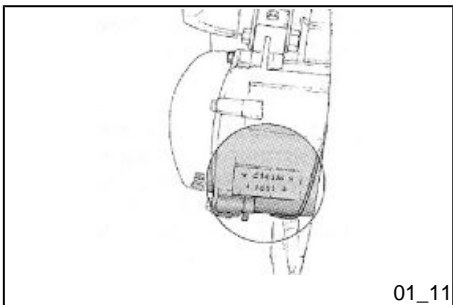
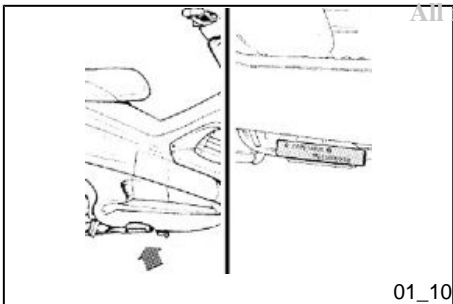

The identification numbers consist of a prefix stamped on the chassis and on the engine, followed by a number. They must be quoted when ordering spare parts. We recommend that you check that the prefix and chassis number stamped on the vehicle correspond with those in the vehicle documents.

**CAUTION**



**BE REMINDED THAT ALTERING IDENTIFICATION REGISTRATION NUMBERS CAN LEAD TO SERIOUS PENAL SANCTIONS (IMPOUNDING OF THE VEHICLE, ETC.).**

# Runner PureJet 50



**Chap. 02**  
**Use**

## Checks

### BEFORE USING YOUR VEHICLE CHECK:

1. Check that the fuel and oil tanks are adequately filled.
2. Rear hub oil level.
3. Tire inflation pressure.
4. Lights and turn indicators.
5. Front and rear brakes.
6. Fluid level in the front and rear brake pump.
7. Coolant

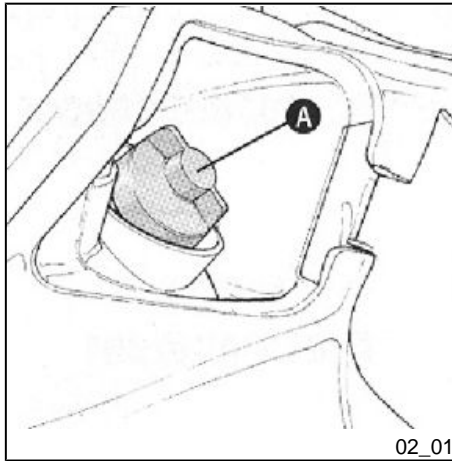

### Refuelling (02\_01, 02\_02, 02\_03)

To open the fuel tank gently push the ignition key on the «ON» and «OFF» positions. Fill fuel tank «A» with unleaded gasoline (minimum octane 95). The rider is informed when the fuel is low by the warning light on the instrument panel. Fill the engine oil tank «B» with recommended engine oil. When the minimum oil level is reached a warning light on the instrument panel will illuminate. This light reminds you to add at least 0.5 ÷ 0.7 liters of new oil at the next refueling, do not travel more than 150 km with the warning light on. The vehicle is equipped with an electronic test of the oil warning light. When the ignition key is set to the «ON» position the warning light must come on for a few seconds before going out if the oil level is above the minimum level. If the warning light fails to illuminate contact an **Authorized Piaggio-Gilera Service Center**. If the fuel mixing device is assembled or disassembled it is necessary to bleed it. Despite this the conductors may not have oil.

Contact an **Authorized Piaggio-Gilera Service Center** to check that the mixing device is in good working order.

*all-guides.com*

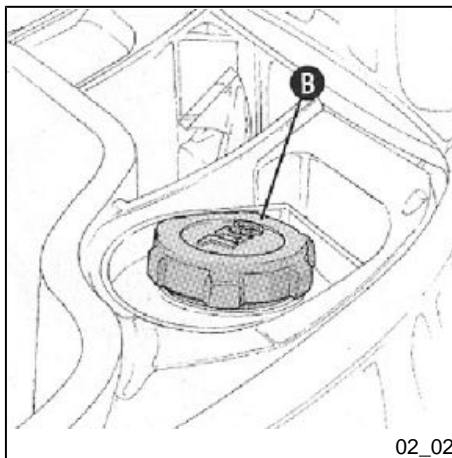

02\_02

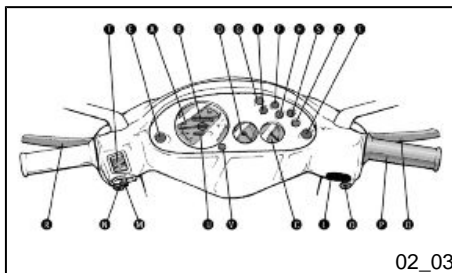

02\_03



**CAUTION**

SHUT OFF THE ENGINE BEFORE REFUELING WITH PETROL. PETROL IS HIGHLY FLAMMABLE. DO NOT LET PETROL SPILL FROM THE TANK OR WHILE REFUELING

**CAUTION**



DO NOT BRING NAKED FLAMES OR CIGARETTES NEAR THE MOUTH OF THE FUEL TANK: FIRE HAZARD. ALSO AVOID INHALING HARMFUL VAPOURS.

**CAUTION**



DO NOT USE THE VEHICLE TO THE COMPLETE EXHAUSTION OF THE FUEL; SHOULD THIS OCCUR, DO NOT ATTEMPT TO START THE ENGINE. TURN THE IGNITION SWITCH TO «OFF» AND TOP-UP THE TANK AS SOON AS POSSIBLE. FAILURE TO FOLLOW THESE GUIDELINES COULD DAMAGE THE FUEL PUMP AND/OR THE CATALYTIC CONVERTER.

**WARNING**



DO NOT RIDE WITH THE FUEL TANK ALMOST EMPTY, LACK OF FUEL CAN DAMAGE THE CATALYTIC CONVERTER.

**CAUTION**



**THE USE OF OILS AND SPARK PLUGS OTHER THAN THOSE RECOMMENDED CAN SHORTEN THE LIFE OF THE ENGINE.**

**Recommended products**

**eni i-Ride PG 2t**

*Synthetic based lubricant for low smoke 2-stroke engines and additives.*

API TC - JASO FC - ISO-L-EGD

**Characteristic**

**Topping up mixer oil reservoir**

Topping up oil reservoir: 0.5 ÷ 0.7 l

**Oil mixer tank**

In plastic, of capacity ~ 1,8 lt. (including reserve ~ 0.400 lt.)

**Tyre pressure**

**CAUTION**



**TYRE PRESSURE SHOULD BE CHECKED WHEN TYRES ARE COLD. INCORRECT TYRE PRESSURE CAUSES ABNORMAL TYRE WEAR AND MAKES RIDING DANGEROUS.**

**TYRES MUST BE REPLACED WHEN THE TREAD REACHES THE WEAR LIMITS SET FORTH BY LAW.**

## **Characteristic**

### **Front tyre pressure**

1.6 bar

### **Tyre pressure (rear wheel)**

**Rear wheel:** 1,8 bar

## **Running in (02\_04)**

### **WARNING**



**DURING THE FIRST 1000 KM DO NOT RIDE THE VEHICLE OVER 80% OF ITS MAXIMUM SPEED. AVOID TWISTING THE THROTTLE GRIP FULLY OR KEEPING A CONSTANT SPEED ALONG LONG SECTIONS OF ROAD. AFTER THE FIRST 1000 KM, GRADUALLY INCREASE SPEED UNTIL REACHING THE MAXIMUM PERFORMANCE.**



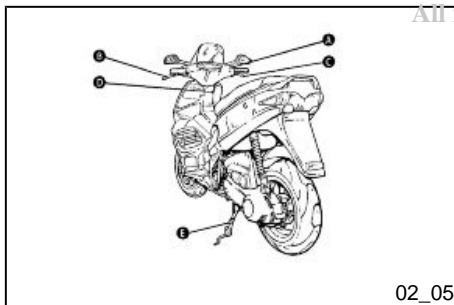

## Starting up the engine (02\_05)

The vehicle is equipped with an automatic transmission system with a direct choke. Always start the engine with the gas control at minimum, and gradually accelerate to pull away. The vehicle has a fuel line tap and a starter device which automatically start when the engine is turned on. To start the engine first pull the rear brake lever «**B**» or front one «**C**» before pressing the starter button «**A**».

**a:** Place the vehicle on its kickstand and check that the rear tire is not touching the ground.

**b:** Keep the throttle at idle speed.

**c:** Insert the ignition key and turn it to "ON". When the key is turned to "ON" the oil reserve light will go on for a few seconds indicating that it is working properly.

**d:** Wait 5 seconds for the complete pressurisation of the fuel feeding circuit.

**e:** Pull the rear brake lever «**B**» or front brake lever «**C**» and then press the starter button.

### CAUTION



**DO NOT CARRY OUT THESE OPERATIONS IN CLOSED AREAS SINCE EXHAUST GASES ARE TOXIC.**



**DO NOT PRESS THE START BUTTON WITH EMPTY TANK, NOR TURN THE KEY SWITCH TO "ON" TO PREVENT DAMAGES TO THE FEEDING PUMP.**



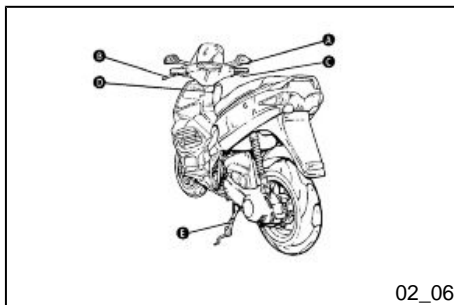

### Difficult start up (02\_06)

Possible causes for engine starting difficulty and suggested actions:

1. In case of total end of fuel. After refuelling the vehicle, carry out the following procedure for 5 times: key set to "ON" for at least 5 seconds - key set to "OFF" for at least two seconds, so as to put the feeding circuit under pressure. Then, proceed to start as usual by pressing button «A» and keeping the gas knob to idle. If the above procedures fail to make the vehicle start, contact an **authorised Piaggio-Gilera Service Centre**.

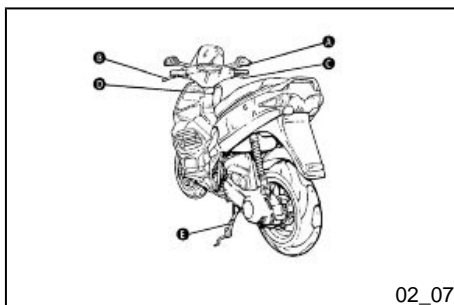

### Stopping the engine (02\_07)

Stop acceleration, then turn the key switch «D» to «OFF» to stop the engine (extractable key).

### Catalytic silencer

CAUTION



**TAMPERING WITH THE CATALYTIC SILENCER MAY CAUSE SEVERE DAMAGE TO THE ENGINE.**

*all-guides.com*

**CAUTION**

**WHEN PARKING THE VEHICLE, DUE TO THE HIGH TEMPERATURES THE CATALYTIC CONVERTER CAN REACH, ALWAYS BE CAREFUL THAT THE MUFFLER DOES NOT COME INTO CONTACT WITH FLAMMABLE MATERIALS, TO AVOID SERIOUS BURNS.**

**CAUTION**

**DO NOT SHUT OFF THE ENGINE WHILE THE VEHICLE IS MOVING. UNBURNED FUEL COULD ENTER THE CATALYTIC CONVERTER AND BURN, CAUSING THE CONVERTER TO OVERHEAT AND POSSIBLY DESTROYING IT.**

**Automatic transmission (02\_08)**

To ensure simple, pleasurable riding, the vehicle is equipped with automatic transmission with regulator and centrifugal clutch. The system is designed to give the best possible performance in terms of both acceleration and consumption, on level ground and uphill, thanks to the adjustments made to engine speed and transmitted torque. If you have to stop on an uphill slope (traffic lights, traffic jam, etc.) only use the brake to keep the vehicle still, leaving the motor running at idling speed. Using the motor to keep the vehicle still can cause the clutch to overheat. This problem is due to the friction of the clutch parts on the clutch bell. It is therefore recommended to avoid conditions of prolonged clutch slippage leading to clutch overheating (for example, as well as the situation described above, riding uphill fully laden on steep slopes or starting off on slopes greater than 25%, etc.):

1. Do not continue riding in such conditions.
2. Let the clutch cool down with the motor at idling speed for a few minutes

## Safe driving (02\_09)

### WARNING



**SOME SIMPLE TIPS ARE PROVIDED BELOW WHICH WILL ENABLE YOU TO USE YOUR VEHICLE ON A DAILY BASIS MORE EASILY AND SAFELY.**

<

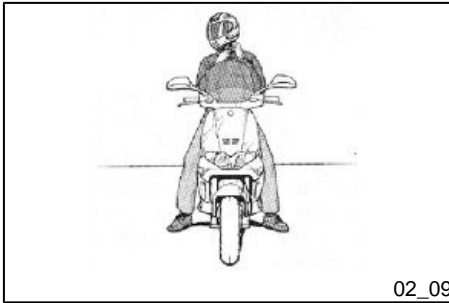

Your ability and your knowledge of the vehicle form the basis of safe riding. We recommend trying out the vehicle in traffic-free zones to get to know your vehicle completely.

### **ALWAYS DRIVE WITHIN YOUR LIMITS**

1. Before riding off, remember to put on your helmet and fasten it correctly.
2. Reduce speed and ride cautiously on uneven roads.
3. Remember that after riding on a long stretch of wet road without using the brakes, the braking effect is initially lower. Under these conditions, it is a good idea to operate the brakes from time to time.
4. Do not brake hard on a wet surface, on dirt tracks or on any slippery road surface.
5. If you have to brake, use both brakes in order to divide the braking action between both wheels.
6. Avoid starting off by mounting the vehicle while it is still resting on its stand. In any case, the rear wheel should not be turning when it comes into contact with the ground, in order to avoid abrupt departures.
7. If the vehicle is used on roads covered with sand, mud, snow mixed with salt, etc., clean the brake disc frequently with mild detergent in order to prevent abrasive substances from building up within the holes, which can result in early wear of the brake pads.

3. Any elaboration that modifies the vehicle's performances, such as tampering with original structural parts is strictly forbidden by law, and renders the vehicle not conforming to the approved type and therefore dangerous to ride.

#### CAUTION



**RIDING UNDER THE INFLUENCE OF ALCOHOL, DRUGS OR CERTAIN MEDICINES CAN BE EXTREMELY DANGEROUS FOR ONESELF AND FOR OTHERS.**

#### CAUTION



**ANY ELABORATION THAT MODIFIES THE VEHICLE'S PERFORMANCES, SUCH AS TAMPERING WITH ORIGINAL STRUCTURAL PARTS IS STRICTLY FORBIDDEN BY LAW, AND RENDERS THE VEHICLE NO LONGER CONFORMING TO THE APPROVED TYPE AND DANGEROUS FOR RIDING.**

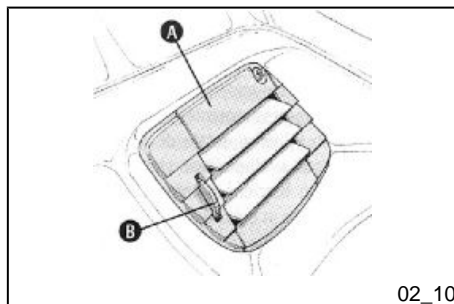

### Air conveyors (02\_10)

The vehicle is provided with 2 air conveyors «A» that allow conveying hot air coming from the cooling fluid radiator towards the driver, to increase the driving comfort in winter or in any case, at very low outside temperature. To open the conveyors, turn control «B» downwards. Turn control «B» upwards to close them.

# Runner PureJet 50



## Chap. 03 Maintenance

## Hub oil level (03\_01, 03\_02, 03\_03)

Remove the oil filler cap/dipstick «A» Unscrew the oil filler plug «B» and drain out all the oil. Screw in the drainage cap again and fill the hub with the specified oil.

### Characteristic

#### Rear hub oil

Quantity: approx. 75 cm<sup>3</sup>

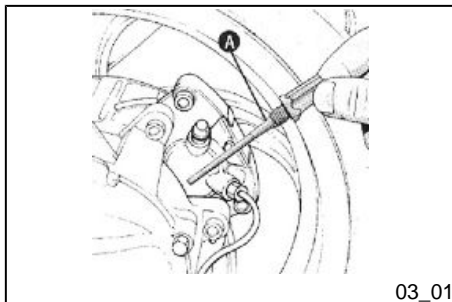

Place the vehicle on its stand on a level surface. Unscrew dipstick "A", dry it with a clean rag and then rescrew it completely. Unscrew the dipstick and check that the oil level reaches the 2nd notch from the bottom of the dipstick. Rescrew the dipstick completely.

#### CAUTION



**RUNNING THE ENGINE WITH INSUFFICIENT LUBRICATION OR WITH THE INADEQUATE LUBRICANTS ACCELERATES WEAR AND TEAR OF THE MOVING PARTS AND CAN CAUSE IRRETRIEVABLE DAMAGE.**

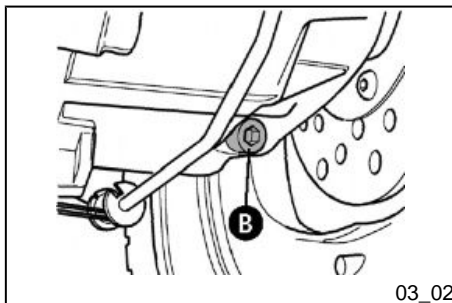

**USED OILS CONTAIN SUBSTANCES HARMFUL TO THE ENVIRONMENT. TO HAVE THE OIL CHANGED, CONTACT AN AUTHORISED PIAGGIO SERVICE CENTRE, WHICH ARE EQUIPPED TO DISPOSE OF USED OILS IN ENVIRONMENTALLY-FRIENDLY MANNER AND IN COMPLIANCE WITH THE REGULATIONS IN FORCE.**

### Recommended products

**AGIP GEAR SAE 80W-90**

*Lubricant for gearboxes and transmissions.*

*all-guides.com*



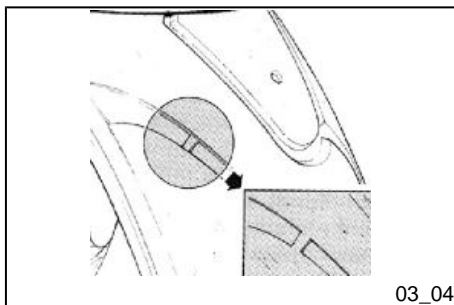
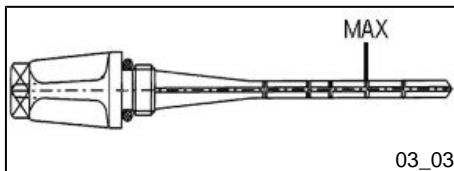

## Tyres (03\_04)

Periodically check the inflation pressure of the front and rear tires. The tires have tread wear indicators "A" and must be replaced as soon as the indicators are visible on the tread. Check also for cuts on the tire walls and uneven wear. Tires must be changed by an authorized service center or a mechanic in possession of the proper tools for fitting tires on your vehicle.

### CAUTION



**TYRE PRESSURE SHOULD BE CHECKED WHEN TYRES ARE COLD. INCORRECT TYRE PRESSURE CAUSES ABNORMAL TYRE WEAR AND MAKES RIDING DANGEROUS.**

**TYRES MUST BE REPLACED WHEN THE TREAD REACHES THE WEAR LIMITS SET FORTH BY LAW.**

### Characteristic

#### Front tyre pressure

1.6 bar

#### Tyre pressure (rear wheel)

Rear wheel: 1,8 bar

## All maintenance Spark plug dismantlement (03\_05, 03\_06)

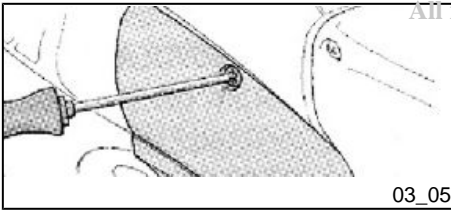

03\_05

Remove the cover, disconnect the plug lead and unscrew the plug with the supplied spark plug pipe wrench "A" supplied. When refitting the plug it should be hand-tightened initially. Be sure to hold the plug at the correct angle. Use the spark plug wrench to tighten the plug fully.

Refit the cover following the above steps in the opposite order, taking care to engage the tabs of the spark plug cap in the central cover.

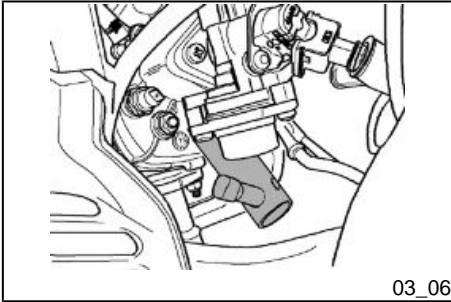

03\_06

### CAUTION



**THE SPARK PLUG MUST BE REMOVED WHEN THE ENGINE IS COLD. THE USE OF SPARK PLUGS OF DIFFERENT THERMAL GRADE FROM THAT REQUIRED OR WITH INAPPROPRIATE THREADS MAY SERIOUSLY DAMAGE THE ENGINE.**

### Characteristic

#### Recommended spark plug type

CHAMPION RG6YCA

#### Electrode gap

0.6 ÷ 0.7 mm

## Removing the air filter (03\_07)

Unscrew the 6 fixing screws remove the cover and extract the filter.

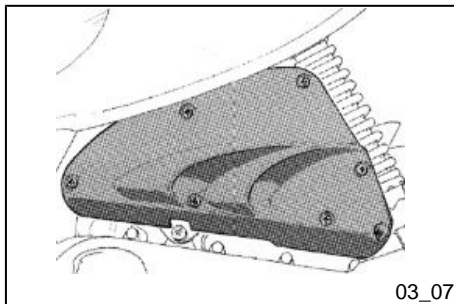

### Air filter cleaning

- 1) Wash the filter with water and a gentle detergent, dry it with a clean rag and blasts of compressed air.
- 2) Soak the filter in a solution of gasoline and recommended oil.
- 3) Remove it from the solution, and squeeze it without wringing it out and let it dry before refitting it on your vehicle.

### Recommended products

#### AGIP FILTER OIL

*Special product for the treatment of foam filters.*

## Cooling fluid level (03\_08, 03\_09)

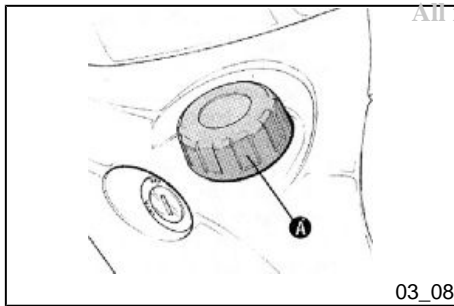

03\_08

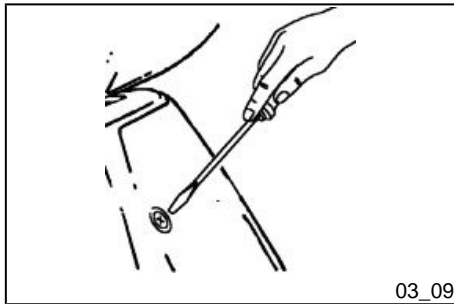

03\_09

The engine cooling is of the forced fluid circulation type. The cooling circuit contains about 0.90 lt. of coolant consisting of 50% mixture of demineralised water and anti-freeze solution based on ethylene glycol and corrosion inhibitors. Recommended coolant, supplied with already mixed fluid ready to use. For a proper operation of the engine, the coolant temperature must range between a minimum value of 60°C and a maximum value of 105° indicated on the special instrument located on the panel. If the needle is in the red zone, stop the engine, let it cool down and check the coolant level; if it regular, contact an **Authorised Piaggio-Gilera Service Centre**.

Following the procedure described below, check the coolant level when the engine is cold every 5,000 km. (4,320 miles).

- A) Put the scooter on the stand.
- B) Remove expansion tank filler cap «A» by turning it anti-clockwise.
- C) Top up whenever the liquid goes below the min. and max level.

The coolant level must always be between the min. and max. level shown by the two references on the expansion tank, which are visible after removing the front shield grille panel. To remove the grille panel click out the Gilera badge and unscrew the screw beneath it, taking care not to damage the paintwork.

If the coolant level is close to minimum, top up when the engine is cold. If you have to top up the coolant too frequently or if the expansion tank is completely empty, there may be a leak in the circuit. In this case take your scooter to your local **Authorised Piaggio-Gilera Service Centre** and have the cooling circuit checked over. The coolant must be changed once every two years. This operation must only be carried out by skilled technical personnel at an **Authorised Piaggio-Gilera Service Centre**.

### WARNING



**TO AVOID THE RISK OF SCALDING, DO NOT UNSCREW THE EXPANSION TANK COVER WHILE THE ENGINE IS STILL HOT.**



**IN ORDER TO AVOID HARMFUL FLUID LEAKS WHILE DRIVING, IT IS IMPORTANT TO MAKE SURE THAT THE LEVEL NEVER EXCEEDS THE MAXIMUM VALUE.**

### **Recommended products**

#### **AGIP PERMANENT SPEZIAL**

*Ethylene glycol-based antifreeze fluid with organic inhibition additives. Red, ready to use.*

ASTM D 3306 - ASTM D 4656 - ASTM D 4985 - CUNA NC 956-16

### **Checking the brake oil level (03\_10, 03\_11)**

The brake fluid reservoirs are equipped with a sight glass «A» it shows the level in the reservoirs.

With sight glass «A» completely covered with fluid, the level is above Min; if level drops the fluid level is considered Min; when no fluid is visible the fluid level is below Minimum.

The brake fluid level may fall due to wear of the brake pads. If the level is less than minimum take your vehicle to an **Authorized Piaggio-Gilera Service Center** for a general check-up of the brakes. If you need to fill up the level, follow the instructions below. Unscrew the two screws «B», remove the reservoir cap «C» and pour in the required quantity of fluid (the brake fluid level must be above minimum). Check the level keeping the reservoir in a horizontal position with the handlebars straight and the vehicle perfectly level.

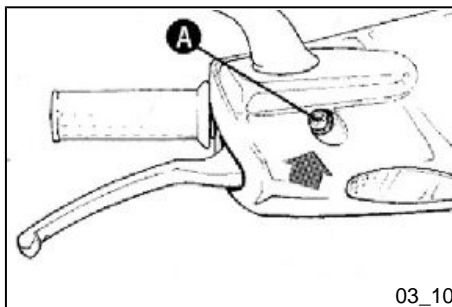

*all-guides.com*

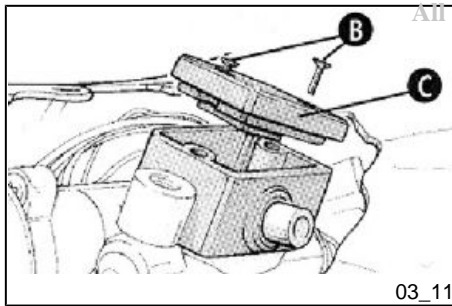
**CAUTION**

TOP-UPS SHOULD ONLY BE CARRIED OUT WITH DOT4 CLASSIFIED BRAKE FLUID.

**CAUTION**

THE BRAKING CIRCUIT FLUID IS HIGHLY CORROSIVE. THEREFORE, WHEN TOPPING UP, AVOID LETTING IT COME INTO CONTACT WITH THE PAINTED PARTS OF THE VEHICLE. THE BRAKING CIRCUIT FLUID IS HYGROSCOPIC, THAT IS, IT ABSORBS HUMIDITY FROM THE SURROUNDING AIR. IF MOISTURE CONTAINED IN THE BRAKE FLUID EXCEEDS A CERTAIN VALUE, THIS WILL RESULT IN INEFFICIENT BRAKING.

**WARNING**

IN NORMAL CLIMATIC CONDITIONS IT IS ADVISABLE TO REPLACE THE ABOVE-MENTIONED FLUID EVERY 2 YEAR. NEVER USE BRAKE FLUID CONTAINED IN CONTAINERS WHICH ARE ALREADY OPEN OR PARTIALLY USED.

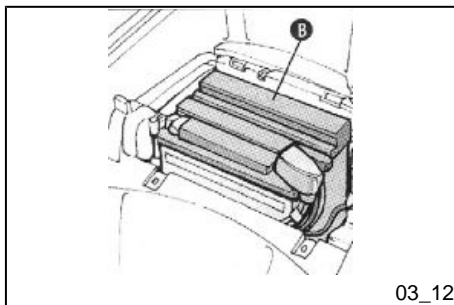

03\_12

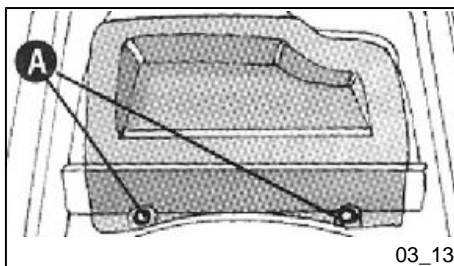

03\_13

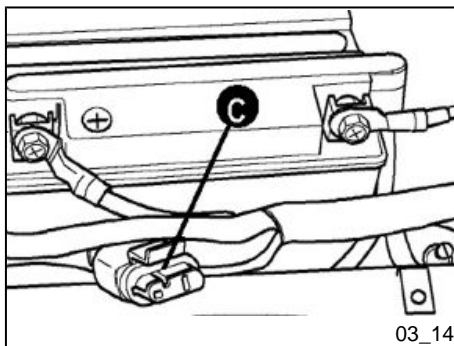

03\_14

To access the battery tip the saddle forwards and unscrew the two screws "A". To release the battery disconnect the leads. The battery is an electronic device that requires regular inspection and servicing. The main points regarding servicing are listed below.

**CAUTION**



**IN ORDER TO AVOID DAMAGING THE ELECTRICAL SYSTEM, NEVER DISCONNECT THE WIRING WHILE THE ENGINE IS RUNNING. DO NOT TIP THE VEHICLE TOO MUCH IN ORDER TO AVOID DANGEROUS LEAKAGE OF THE BATTERY ELECTROLYTE.**

**CAUTION**



**ELECTROLYTE CONTAINS SULPHURIC ACID: AVOID CONTACT WITH EYES, SKIN AND CLOTHES. IN CASE OF ACCIDENTAL CONTACT, RINSE WITH ABUNDANT WATER AND CONSULT A DOCTOR.**

**WARNING**



**USED BATTERIES ARE HARMFUL FOR THE ENVIRONMENT. COLLECTION AND DISPOSAL SHOULD BE CARRIED OUT IN COMPLIANCE WITH REGULATIONS IN FORCE.**



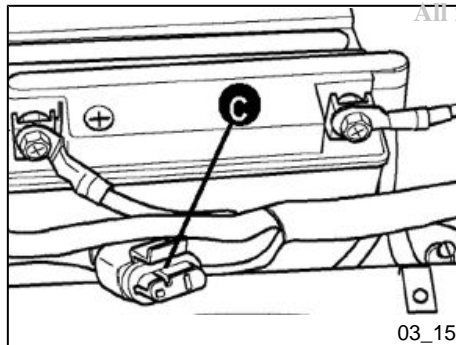

### All maintenance operations (03\_15) **Checking the electrolyte level (03\_15)**

Check regularly that the electrolyte is at maximum level. Fill up **only with distilled water**. If the battery needs filling too frequently check the electrics: the battery is probably working in overload conditions which will lead to rapid deterioration. Diagnostic outlet "C" for use by **authorised Piaggio-Gilera Service Centres**.

### Long periods of inactivity

Battery performance will be poor if the vehicle is not used for a long time. This is the result of the natural phenomenon of battery discharging, and may be due to residual absorption by vehicle components with constant power consumption. Poor battery performance may also be due to environmental conditions and the cleanliness of the poles. In order to avoid difficult starts and/or irreversible damage to the battery, follow any of these steps:

- **At least once a month** start the engine and run it slightly above idle speed for 10-15 minutes. This keeps all the engine components, as well as the battery, in good working order.

- Take your vehicle to a garage (as indicated in the «Vehicle not used for extended periods» section) to have the battery removed. Have the battery cleaned, charged fully and stored in a dry, ventilated place. Recharge **at least once every two months**.

#### **N.B.**

**THE BATTERY MUST BE CHARGED WITH A CURRENT EQUAL TO 1/10 OF THE RATED CAPACITY OF THE BATTERY AND FOR NOT LONGER THAN 10 HOURS. CONTACT AN AUTHORISED SERVICE CENTRE TO CARRY OUT THIS OPERA-**

All manuals and user guides at [all-guides.com](http://all-guides.com)

**TION SAFELY. WHEN REFITTING THE BATTERY MAKE SURE THE LEADS ARE CORRECTLY CONNECTED TO THE TERMINALS.**

**WARNING**



**DO NOT DISCONNECT THE BATTERY CABLES WITH THE ENGINE RUNNING, THIS CAN CAUSE IRREPARABLE DAMAGE TO THE VEHICLE'S ELECTRONIC CONTROL UNIT.**

**WARNING**



**USED BATTERIES ARE HARMFUL FOR THE ENVIRONMENT. COLLECTION AND DISPOSAL SHOULD BE CARRIED OUT IN COMPLIANCE WITH REGULATIONS IN FORCE.**

### **Fuses (03\_16, 03\_17)**

The electric system is provided with two 1.5 A fuses located in the battery compartment, and with two 7.5 A fuses located under the front grill. The table shows the features of the fuses present on the vehicle

#### **FUSES**

N° 1 fuse 15A	Basic power plant supply
	Air injector

	Coil injector H.V. coil Battery charge
N° 1 fuse 15A	Fuel pump Power plant supply under lock
N° 1 fuse 7,5A	Lighting
N° 1 fuse 7,5A	Warning lights Consents Stop light Flasher lights Horn

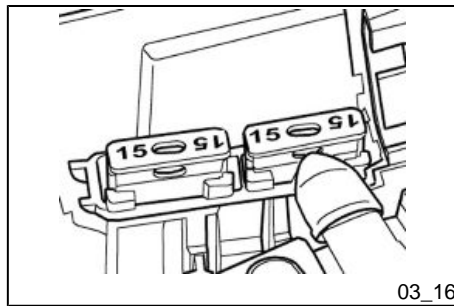

*all-guides.com*

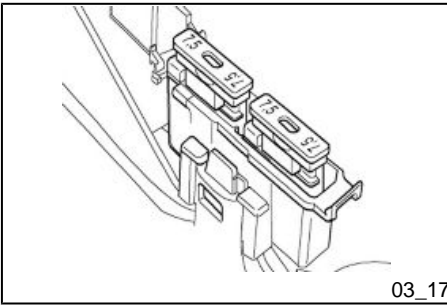

### Front light group (03\_18, 03\_19)

To turn the headlights on (no. 2 lamps for dipped beams), remove the central cover by turning the screw. Then unscrew the 3 screws that secure the light. Then remove the light from the front, remove the 2 rubber protection caps. Turn the clips to remove the high beam bulbs. To refit carry out the above steps in the reverse order.

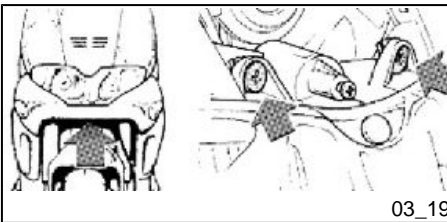
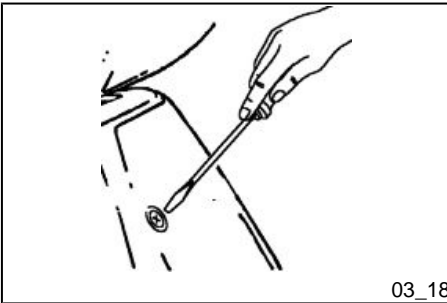

### All maintenance instructions

## Headlight adjustment (03\_20, 03\_21)

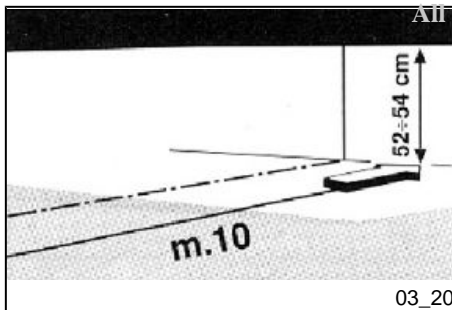

Put the unloaded vehicle on level, even ground at a distance of 10 m. from a screen that is sufficiently darkened and make sure that the vehicle axis is at right angles to the screen. Mark the screen with a horizontal line that is 52-54 cm. from the ground. Start the engine, switch on the headlight dipped beam and position it so that the boundary between the brightly illuminated area and the surrounding area is no higher than the line you have drawn.

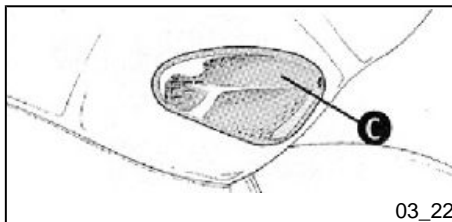
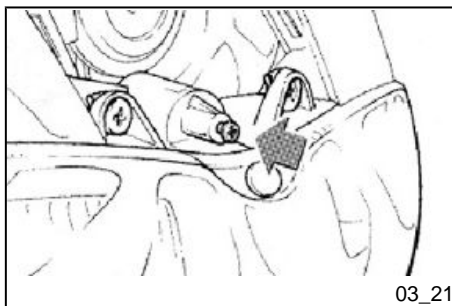

## Front direction indicators (03\_22)

To replace the front turn indicator bulbs, unscrew the screws from the relative glass covers "C". The bulbs have a bayonet fitting, so to remove them simply press down slightly, turn the bulb anticlockwise by about 30°, and remove them.

### All rights reserved. Visit [www.all-guides.com](http://www.all-guides.com)

#### Rear optical unit (03\_23)

To change the tail-light and rear turn indicator bulbs unscrew the screws "D" on the central plastic cover (the turn indicator covers are attached to it). To remove the bulbs press them slightly, turning counterclockwise for around 30° and then extract them. To refit carry out the above steps in the reverse order.

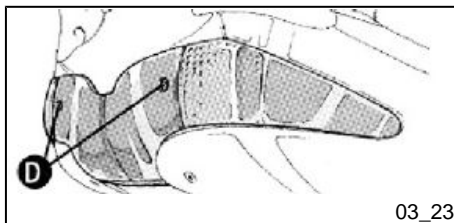

03\_23

#### Rear-view mirrors (03\_24)

To adjust the position of the rod remove rubber cap «A» and loosen the screws, then put the rod in the appropriate position and tighten the screws. The mirror is fitted with a ball and socket joint so that it can be adjusted by applying slight pressure to the edges.

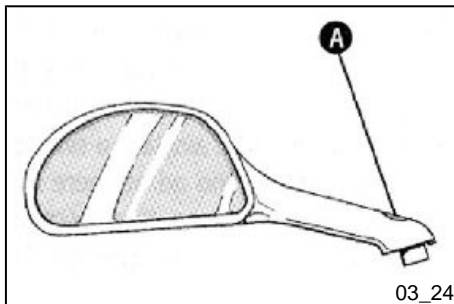

03\_24

#### Front and rear disc brake (03\_25, 03\_26)

The brake disc and pad wear is automatically compensated, therefore it has no effect on the functioning of the front and rear brakes. For this reason it is not necessary to adjust the brakes. An excessively elastic brake lever stroke may indicate the presence of air in the braking circuit or an irregular brake operation. In this case, mainly due to the importance of brakes to guarantee safe riding conditions, the vehicle should be taken to an **Authorised Piaggio-Gilera Service Centre** in order to be checked.

#### CAUTION



**BRAKING SHOULD BEGIN AFTER ABOUT 1/3 OF THE BRAKE LEVER STROKE.**

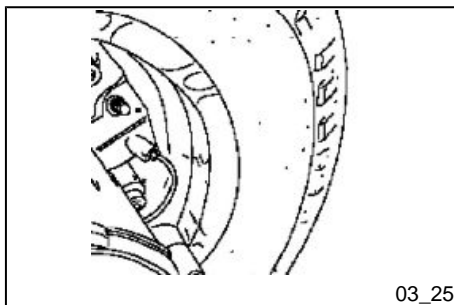

03\_25

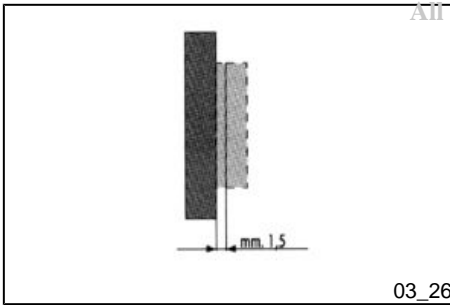

**CHECK THE BRAKE PADS REGULARLY (EVERY 5000 KM). IF THE THICKNESS OF ONE OR BOTH PADS IS IN THE REGION OF 1.5 MM, BOTH PADS MUST BE CHANGED. THIS OPERATION MUST BE CARRIED OUT AT AN AUTHORISED PIAGGIO-GILERA SERVICE CENTRE. AFTER REPLACING THE BRAKE PADS DO NOT USE THE VEHICLE BEFORE HAVING USED THE BRAKE LEVER SEVERAL TIMES IN ORDER TO ALLOW THE PADS TO SETTLE AND THE LEVER STROKE TO BE SET TO THE CORRECT POSITION.**

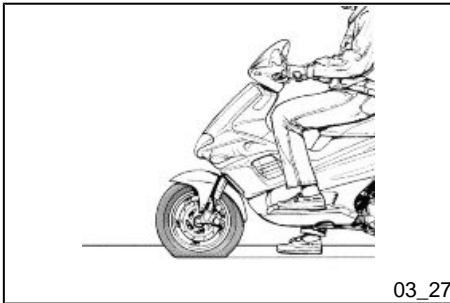

### **Puncture (03\_27)**

The vehicle is equipped with Tubeless tyres. When there is a puncture, Tubeless tyres -unlike balloon tyres- go flat very slowly. This offers greater riding safety. A tyre that goes flat very slowly can be repaired with an "INFLATE AND REPAIR" spray. Tyres should be later fully repaired at an **Authorised Piaggio-Gilera Service Centre**.





Prepare the vehicle as follows:

- 1) Clean the vehicle.
- 2) With the engine stopped and the piston at the bottom of its stroke , **remove the spark plug** and pour about 1÷2 cc. engine oil into the cylinder. Then turn the engine over a few times using the kick-starter and refit the spark plug.then,start the starter motor 3÷4 times for 2-3 seconds .
- 3) Drain the fuel tank and coat unpainted metal parts with protective grease;position the vehicle so that the tires ar not resting on the ground by placing wood blocks under it.
- 4) For the battery , follow the procedure described on the section «Battery».

### **Recommended products**

#### **eni i-Ride PG 2t**

*Synthetic based lubricant for low smoke 2-stroke engines and additives.*

API TC - JASO FC - ISO-L-EGD

### **Cleaning the vehicle**

Use a low pressure jet of water to soften the caked dirt and mud deposited on the painted surfaces. Once softened, sponge off mud and dirt using a car body sponge soaked in a car body shampoo and water solution (2-4% of car shampoo in water). Then rinse with abundant water, and dry with a shammy cloth. For the engine exterior, use petrol, a brush and clean cloths. Petrol can damage paintwork. Remember that any polishing with silicone wax must always be preceded by washing.

*all-guides.com*

**WARNING**



To avoid the appearance of oxidations, wash the vehicle every time it is used in certain areas or in special conditions of:

- Environmental / seasonal conditions: use of salt, de-icer chemical products on the road in winter.
- Air pollution: city and/or industrial areas.
- Salinity and humidity of the atmosphere: marine areas, hot and wet weather.

**WARNING**



- Prevent deposits from remaining on the bodywork, industrial and pollutant residual dust, tar spots, dead insects, bird droppings, etc.
- Do not park the vehicle under the trees. In some seasons, in fact, residues, resins, fruits or leaves may fall from the trees, containing chemicals that are harmful to the paintwork.

**CAUTION**



**DETERGENTS POLLUTE WATER. THEREFORE THE VEHICLE SHOULD BE WASHED IN AN AREA EQUIPPED FOR THE COLLECTION AND PURIFICATION OF THE LIQUIDS USED.**



**NEVER WASH THE VEHICLE UNDER DIRECT SUNLIGHT, ESPECIALLY IN SUMMER WHEN THE BODYWORK IS STILL HOT, AS THE CAR SHAMPOO MAY DRY BEFORE BEING RINSED OFF, AND COULD DAMAGE THE PAINTWORK. NEVER USE RAGS SOAKED IN PETROL OR DIESEL OIL TO CLEAN THE PAINTED OR PLASTIC SURFACES, IN ORDER TO PREVENT THEM LOSING THEIR SHINE AND MECHANICAL CHARACTERISTICS.**

**WARNING**

**WHEN WASHING THE ENGINE WITH A HIGH-PRESSURE WATER JET:**

- **ONLY USE FAN SPRAY JETS.**
- **KEEP NOZZLE AT LEAST 60 CM AWAY FROM THE VEHICLE**
- **DO NOT USE WATER AT TEMPERATURES ABOVE 40°C.**
- **DO NOT DIRECT THE JET AT THE CARBURETTOR, THE ELECTRIC CABLES, THE COOLING SLITS IN THE TRANSMISSION COVER AND THE SPIRAL COVER.**

**DIFFICULTY STARTING**

No fuel in tank	Refuel
Filters, jets or carburetor clogged or dirty.	Contact an <b>Authorized Piaggio-Gilera Service Center</b> .
Dead battery.	Kick-start. Install new battery..

### **IRREGULAR FIRING**

No spark on spark plug. High voltage: this inspection should be carried out by a trained mechanic.

Make sure the electrodes are correctly adjusted (0.6-0.7 mm).  
Make sure the electrodes are clean (clean with pure gasoline and a metal brush or abrasive cloth).  
Check the spark plug insulation if there are cracks or it is broken replace the spark plug. If the spark plug is in good condition, contact an **Authorized Piaggio-Gilera Service Center**.

### **POOR COMPRESSION**

Spark plug bore thread damaged; head bolts insufficiently torqued

Contact an **Authorized Piaggio-Gilera Service Center**.

### **HIGH FUEL CONSUMPTION AND POOR PERFORMANCE**

Dirty or clogged air filter.

Wash with water and detergent and lubricate (see the cleaning instruction). If problems persist, turn to an **Authorized Piaggio-Gilera Help Point**.

### **INSUFFICIENT BRAKING**

Greasy disc. Worn pads.	Contact an <b>Authorised Piaggio-Gilera Service Centre</b> .
-------------------------	--

Air in the brake assembly.	Contact an <b>Authorised Piaggio-Gilera Service Centre</b> .
----------------------------	--

### **POOR SUSPENSION**

Deterioration hydraulic material; worn stroke end bumpers; worn shock absorber attachment points.	Contact an <b>Authorized Piaggio-Gilera Service Center</b> .
---	--

### **IRREGULAR OPERATION OF AUTOMATIC TRANSMISSION**

Worn roller case or drive belt	Contact an <b>Authorized Piaggio-Gilera Service Center</b> .
--------------------------------	--



*all-guides.com*



# Runner PureJet 50



## Chap. 04 Technical data

**DATA**

ENGINE	single cylinder; 2-stroke
Bore x stroke	40 X 39.3 mm
Displacement	49,4 cm <sup>3</sup>
Compression ratio	11,5 ± 0,9
Ignition advance (before T.D.C. )	Variable-managed by the electronic unit controlling the ignition installation
Throttle body	20 BING 71/20/104
Recommended spark plug type	CHAMPION RG6YCA
Max. speed	According to current legislation

**TECHNICAL DATA**

Maximum length	1780 mm.
Overall width	720 mm.
Maximum height	830 mm.
Wheelbase	1290 mm
Fuel system	Gasoline-oil mixture through 2 injectors in series, automatic mixing (with variable flow rate according to engine speed and gas

	valve opening, fuel pump in electric line
Fuel intake	Through the reed valve on the case integrated in the injection system.
Lubrication	Engine lubrication (pistone, cylinder, crankshaft, bearings, air compressor) carried out by the oil introduced in the pump case along with the washing air.
Cooling	Forced-circulation coolant system.
Transmission	Expanding pulley type automatic speed variator with vee belt, centrifugal clutch, gear final drive and forced air cooling.
Oil mixer tank	In plastic, of capacity ~ 1,8 lt. (including reserve ~ 0.400 lt.)
Topping up mixer oil reservoir	Topping up oil reservoir: 0.5 ÷ 0.7 l
Rear hub oil	Quantity: approx. 75 cm <sup>3</sup>
Tank capacity	In plastic, of capacity 12lt.
Front suspension	with telescopic fork.
Rear suspension	With coaxial spring and hydraulic shock absorber. Chassis to engine support with swinging arm.
Wheels	Light alloy 3.50 X 12" rims.
Front tyre	without inner tube 120/70-12"
Rear tyre	without inner tube 130/70-12"
Exhaust system	Combined expansion chamber absorption type, with double

	catalytic converter and SAS plate system.
Electronic ignition	Electronic ignition system, with integrated A.T. coil.
Chassis	made of welded tubular steel with sheet metal reinforcement.
Front brake	disc brake with hand activated hydraulic control (lever on the extreme right of the handlebars).
Rear brake	disc brake with hand activated hydraulic control (lever on the extreme left of the handlebars).
Curbside weight	98 Kg.
Maximum load	Driver only.

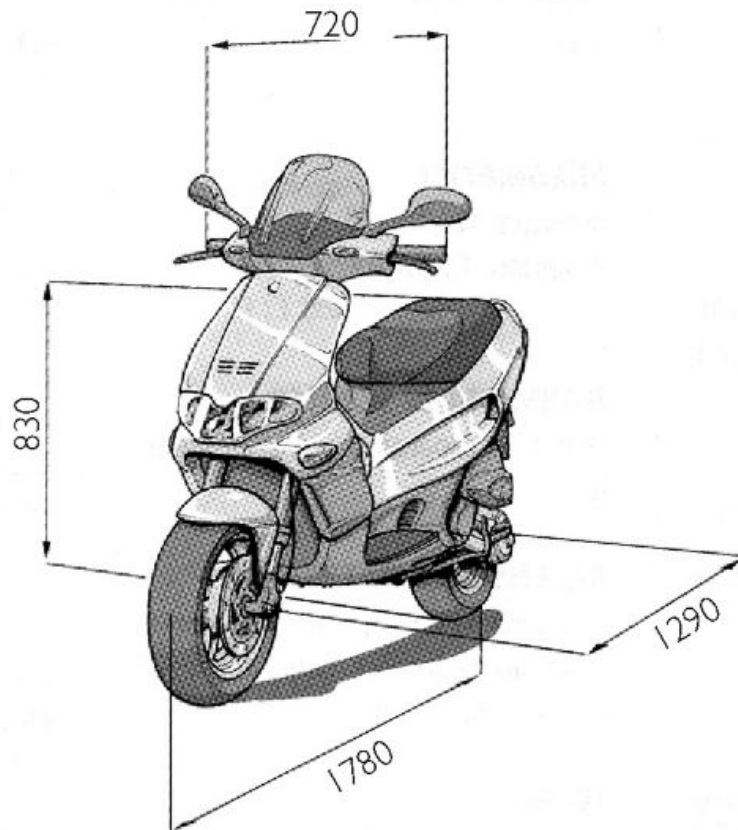

*all-guides.com*

## **Toolkit**

Wrenches: one box-spanner (13 -21 mm); one twin screwdriver. The tools are located under the seat in a specific container.

# Runner PureJet 50



## Chap. 05 Spare parts and accessories



## Warnings (05\_01)

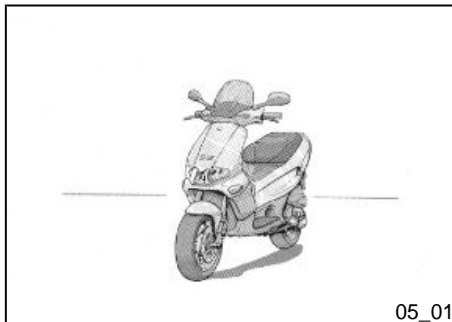

### CAUTION



**WE STRONGLY RECOMMEND USING ORIGINAL PIAGGIO-GILERA SPARE PARTS, THE ONLY PARTS THAT GUARANTEE THE SAME QUALITY LEVEL AS THE ORIGINAL PARTS ASSEMBLED ON THE VEHICLE.**

**IT SHOULD BE REMEMBERED THAT USING NON-ORIGINAL SPARE PARTS CAUSES YOUR WARRANTY RIGHTS TO EXPIRE.**

### CAUTION



**PIAGGIO-GILERA MARKETS ITS OWN LINE OF ACCESSORIES, WHICH ARE COVERED BY A MANUFACTURER'S WARRANTY ON THE BASIS OF THEIR USE. IT IS THEREFORE ABSOLUTELY NECESSARY TO CONTACT AN AUTHORISED PIAGGIO-GILERA DEALER OR SERVICE CENTRE TO CHOOSE THEM AND HAVE THEM CORRECTLY ASSEMBLED. THE USE OF NON-ORIGINAL ACCESSORIES MAY AFFECT THE STABILITY AND OPERATION OF YOUR VEHICLE AND REDUCE SAFETY LEVELS WITH POTENTIAL RISKS FOR THE RIDER.**

# Runner PureJet 50



**Chap. 06**  
**Scheduled**  
**maintenance**

**Scheduled servicing table (06\_01)**

06\_01

Adequate maintenance is fundamental to ensuring long-lasting, optimum operation and performance of your vehicle.

To this end, a series of checks and maintenance operations (at the owner's expense) have been suggested, which are included in the summary table on the following page. Any minor faults should be reported without delay to an **Authorised Service Centre or Dealer** without waiting until the next scheduled service to solve it.

It is indispensable to have your vehicle serviced to the prescribed intervals of time, even if you have not reached the predicted mileage. Punctual vehicle servicing is necessary for the correct use of the guarantee. For any further information concerning Warranty procedures and 'Scheduled Maintenance', please refer to the 'Warranty Booklet'.

**SCHEDULED MAINTENANCE TABLE**

km x 1,000	1	5	10	15	20	25	30	35	40	45	50	55	60
Safety fasteners	I		I		I		I		I		I		I
Spark plug/Electrode gap		R	R	R	R	R	R	R	R	R	R	R	R
Drive belt		I	R	I	R	I	R	I	R	I	R	I	R
Mixer belt					R				R				R
Air filter		C	C	C	C	C	C	C	C	C	C	C	C
Fuel filter			R		R		R		R		R		R
Electrical system and battery	I	I	I	I	I	I	I	I	I	I	I	I	I
Brake levers	L	L	L	L	L	L	L	L	L	L	L	L	L
Coolant *		I	I	I	I	I	I	I	I	I	I	I	I
Brake fluid*	I	I	I	I	I	I	I	I	I	I	I	I	I

*all-guides.com*

km x 1,000	1	5	10	15	20	25	30	35	40	45	50	55	60
Transmission gas mixer	A	A	A	A	A	A	A	A	A	A	A	A	A
Hub oil	R	I	R	I	R	I	R	I	R	I	R	I	R
Brake pads		I	I	I	I	I	I	I	I	I	I	I	I
Tyre pressure and wear	I	I	I	I	I	I	I	I	I	I	I	I	I
Headlight			A		A		A		A		A		A
Vehicle and brake road test	I	I	I	I	I	I	I	I	I	I	I	I	I
Radiator					C				C				C
Odometer gear	L		L	L	L	L	L	L	L	L	L	L	L
CVT rollers			R		R		R		R		R		R
Suspension			I		I		I		I		I		I
Steering	A		A		A		A		A		A		A
Transmission			L		L		L		L		L		L

*I: INSPECT AND CLEAN, ADJUST, LUBRICATE OR REPLACE IF NECESSARY*

*C: CLEAN, R: REPLACE, A: ADJUST, L: LUBRICATE*

*\* Replace every 2 years*

## RECOMMENDED PRODUCTS TABLE

Product	Description	Specifications
AGIP GEAR SAE 80W-90	Lubricant for gearboxes and transmissions.	API GL-4
eni i-Ride PG 5W-40	Synthetic based lubricant for high-performance four-stroke engines.	JASO MA, MA2 - API SL - ACEA A3

Product	Description	Specifications
AGIP FILTER OIL	Special product for the treatment of foam filters.	-
AGIP GP 330	Water repellent springy calcium spray grease.	R.I.D./A.D.R. 2 10°b) 2 R.I.Na. 2.42 - I.A.T.A. 2 - I.M.D.G. class 2 UN 1950 Pag. 9022 EM 25-89
eni i-Ride PG 2t	Synthetic based lubricant for low smoke 2-stroke engines and additives.	API TC - JASO FC - ISO-L-EGD
AGIP PERMANENT SPEZIAL	Ethylene glycol-based antifreeze fluid with organic inhibition additives. Red, ready to use.	ASTM D 3306 - ASTM D 4656 - ASTM D 4985 - CUNA NC 956-16

## TABLE OF CONTENTS

### **A**

Air filter: 29

### **B**

Battery: 33  
Brake: 31, 39

### **C**

Checks: 16

### **D**

Disc brake: 39

### **F**

Fuses: 35

### **H**

Headlight: 38

Horn: 11

Hub oil: 26

### **I**

Identification: 14

### **K**

Key switch: 10

Keys: 13

### **L**

Light switch: 12

### **M**

Maintenance: 25, 55

Mirrors: 39

### **P**

Puncture: 40

### **R**

Refuelling: 16

### **S**

Saddle: 12

Scheduled maintenance: 55

Spark plug: 28

Start-up: 12

Switch: 10–12

### **T**

Technical Data: 47

Toolkit: 52

Transmission: 22

Tyre pressure: 18

Tyres: 27

### **V**

Vehicle: 7, 41



The descriptions and images in this publication are given for illustrative purposes only and are not binding. While the basic characteristics as described and illustrated in this booklet remain unchanged, Piaggio & C. S.p.A. reserves the right, at any time and without being required to update this publication beforehand, to make any changes to components, parts or accessories, which it considers necessary to improve the product or which are required for manufacturing or construction reasons.

Not all versions/models shown in this publication are available in all countries. The availability of each model should be checked at the official PIAGGIO sales network.

© Copyright 2012 - Piaggio & C. S.p.A. All rights reserved. Reproduction of this publication in whole or in part is prohibited.

Piaggio & C. S.p.A. Viale Rinaldo Piaggio, 25 - 56025 PONTEDERA (PI), Italy

[www.piaggio.com](http://www.piaggio.com)